

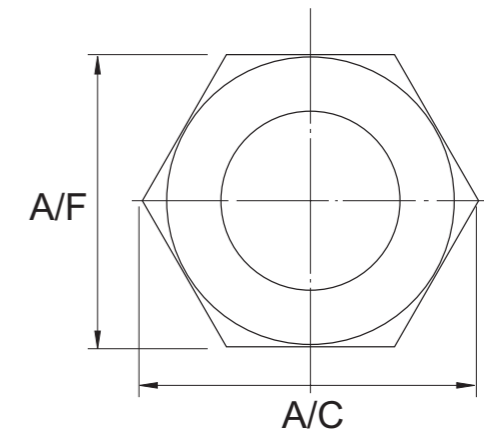

SIZE	CABLE DIA		ISO ENTRY THREAD		PROTRU SION LENGTH APPROX F	HEXAGONAL SIZE		P/N
	A	B	DIA	LENGTH		A/F	A/C	
	MAX	MAX	C	D				
16S	8.0	12.0	M16	9	20	20	22	ABW-16S
16	8.6	13.5	M16	9	20	20	22	ABW-16
20S	12.3	17	M20	9	20	22	24	ABW-20S
20	14.3	20	M20	9.5	20	25	27	ABW-20
25S	19	23.25	M25	9.5	22	31	34	ABW-25S
25	20.4	27	M25	9.5	22	33.5	37	ABW-25
32S	23.5	28.5	M32	9.5	25	35	38.5	ABW-32S
32	26.5	33.5	M32	9.5	25	40	45	ABW-32
40S	31	37.5	M40	12.5	25	44.5	49	ABW-40S
40	33	41.5	M40	12.5	25	48.5	54	ABW-40
50S	39.5	48	M50	12.5	28	56.5	63.5	ABW-50S
50	44	54	M50	12.5	30	61	68	ABW-50
63S	50.5	60.5	M63	14	33	69.5	77	ABW-63S
63	56	65	M63	14	33	75.5	84.5	ABW-63
75S	62.5	72	M75	14	40	83.5	93	ABW-75S
75	67.5	78.5	M75	14	40	89.5	99	ABW-75
90S	75	85	M90	20	48	100	110	ABW-90S
90	78	88.5	M90	20	48	102	115	ABW-90

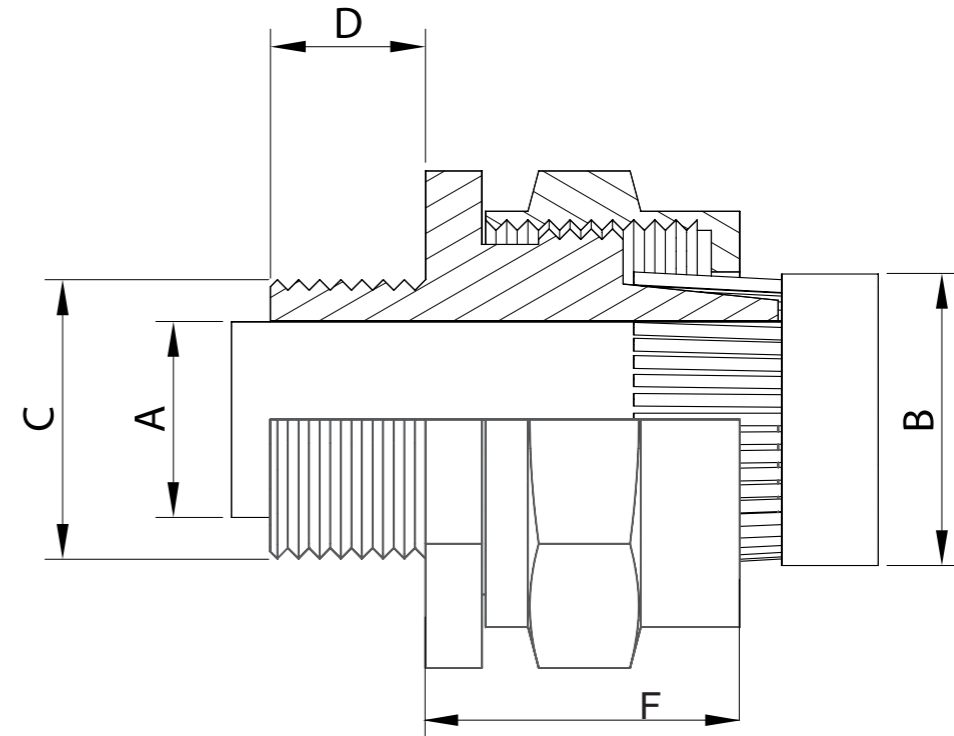

Material: Brass
 Finish: Natural
 All dimensions mentioned are in mm. Standard tolerance applicable

Title: BW INDUSTRIAL BRASS GLAND	SHEET 1/1	SCALE Not to Scale
Drawing No: ABW/01/19		
DRAWN 01/01/2019		
CHECK		
APPR. NJG		
ISSUED		
REV		
CUSTOMER		