

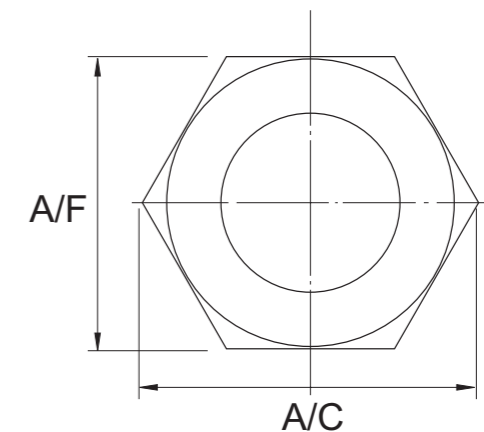

SIZE	OVERALL CABLE DIA		ISO ENTRY THREAD		PROTRU SION LENGTH APPROX F	HEXAGONAL SIZE		P/N
	A		DIA	LENGTH		A/F	A/C	
	MIN	MAX	C	D				
16S	4	7	M16	10	20	21	24	AA2-16S
16	5.5	8.5	M16	10	22	21	24	AA2-16
20S	8.5	11.5	M20	10	24	22	24	AA2-20S
20	11	14	M20	10	24	24	26	AA2-20
25S	13.5	17.5	M25	10	25	27	30	AA2-25S
25	16	20	M25	10	26	30	33	AA2-25
32S	19	23	M32	13	28	36	40	AA2-32S
32	22	26	M32	13	38	36	40	AA2-32
40S	24	29	M40	15	31	44	49	AA2-40S
40	28	34	M40	15	31	46	50	AA2-40
50S	35	40	M50	15	33	55	61	AA2-50S
50	39	44	M50	15	33	58	64	AA2-50
63S	44	50	M63	15	35	67	74	AA2-63S
63	50	55	M63	15	35	69	76	AA2-63
75S	55	62	M75	15	35	78	87	AA2-75S
75	59	65	M75	15	35	81	90	AA2-75
90S	65	75	M90	20	50	100	112	AA2-90S
90	72	78	M90	20	50	100	112	AA2-90
100	83	89	M100	20	50	112	125	AA2-100

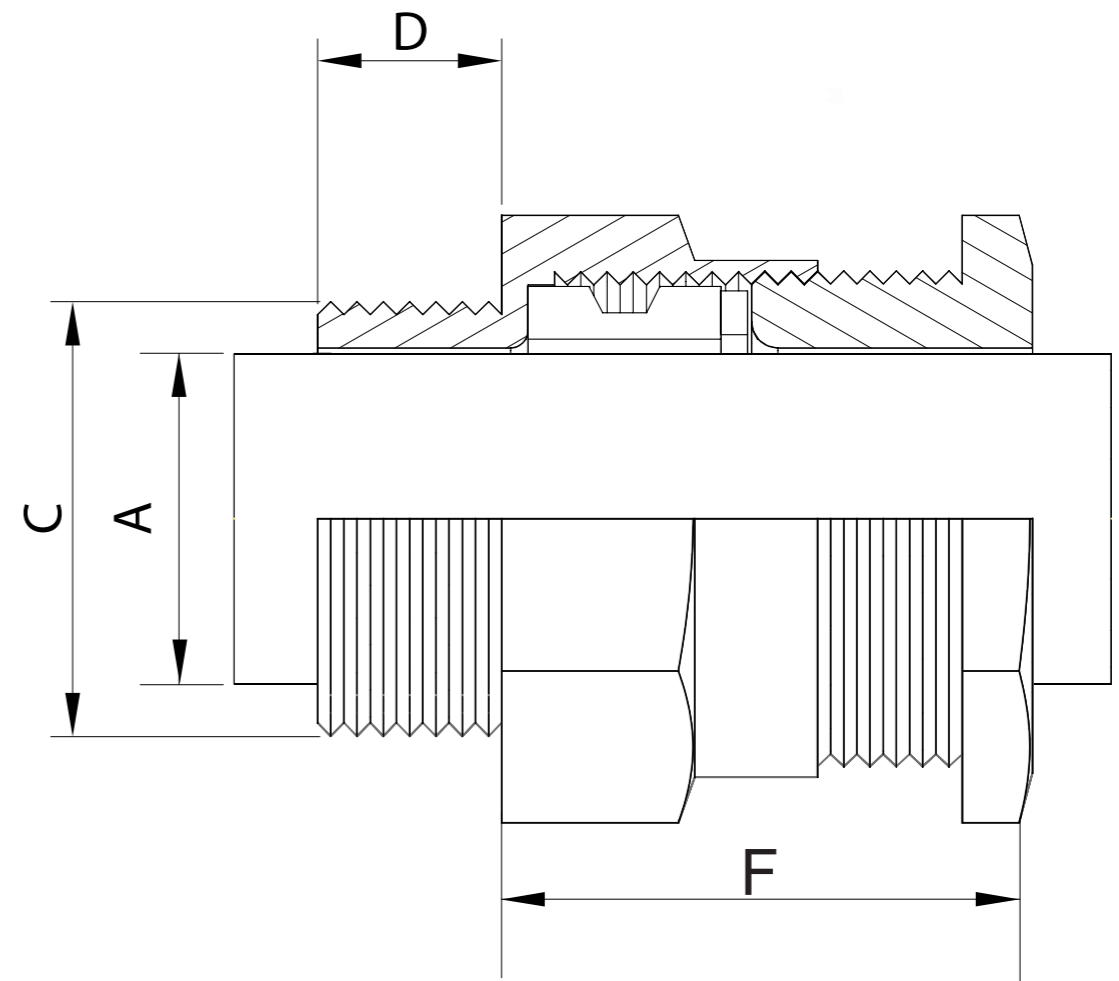

Material: Brass
 Finish: Natural
 All dimensions mentioned are in mm. Standard tolerance applicable

Title: A2 INDUSTRIAL BRASS GLAND	SHEET 1/1	SCALE Not to Scale
Drawing No: AA2/01/19		
DRAWN 01/01/2019		
CHECK		
APPR. NJG		
ISSUED		
REV		
CUSTOMER		